

JIANGSU RUDONG GENERAL MACHINERY CO.LTD

LOAD TEST REPORT

SI.NO.: QR350-00409

Sample source		Set up at plant				
Description	Casing Elevator	Type	TA 4.1/2"/100	Qty.	1Pcs	
Method of sample	100%	Sample Qty.	1	Sample No	00409	
Test std	API Spec 8A	Character	Leave factory	Condition	20°C	
Test equipment	Name	Test-bed of compute control	Type	YEW-10000F	Equipment No.	301
	Precision	±1.0%	Period of validity	2011.8.6	Test Date	2010.8.7
Load rating	100ton	Test load	150ton	Load time	5 mins	

RESULT

Actual test load	150ton(1350kN)	Load-Time
------------------	----------------	-----------

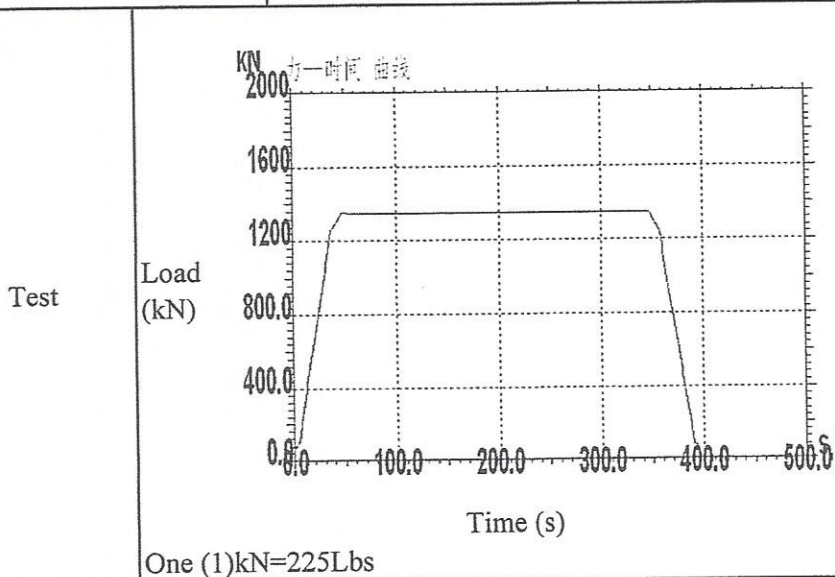

TEST RESULT:

OK

Remark

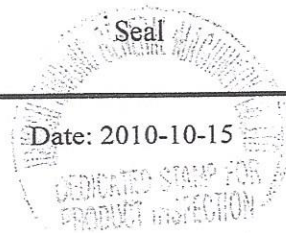

Inspector : Song Jianhua

Engineer: Yin Zhigao

Date: 2010-10-15

# Jiangsu Rudong General Machinery CO.,Ltd.

## MAGNETIC PARTICLE INSPECTION CERTIFICATE

NO.:QR049

Part Name	Casing Elevator	Type	TA 4.1/2"/100
Dispatch No.	00409	Qty.	1 (pcs)
Material	Alloy Steel	Face estate	12.5/ ✓
Heat treatment estate	Quench and Temper	Area thickness	See below
Instrument Model	CEW-6000	Method of Magnetization	Continuum
Method of Display	Fluorescence	Sensitivity	A 15/100
Blacklight lamp	>800uW/cm <sup>2</sup>	Acceptance Std.	GB9444 ASTME709

Test extent and place of assess casing:

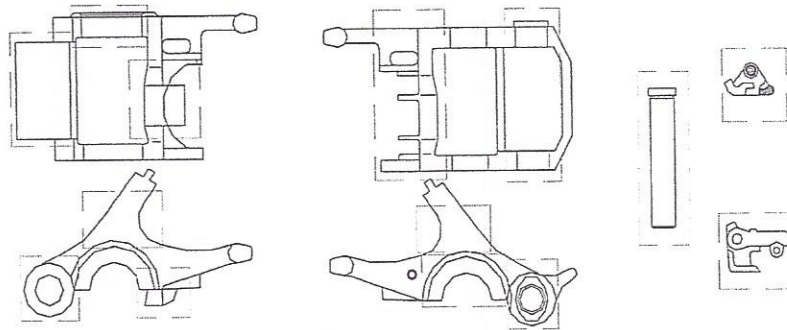

Find type of disfigurement and dimension(see above drawing)

Nonexistence

Quality grade of assess and /or conclusion:

Grade I /OK

Inspector	Xia Shupeng	Auditing	Wu Zengyi	Date(badge of department)	<p style="text-align: center;">2010-10-15</p>
-----------	-------------	----------	-----------	---------------------------	---